



Introduction to Bluetooth Tech

S.M. Riazul Islam, PhD



Bluetooth Overview

- Wireless technology for short-range voice and data communication
- Low-cost and low-power
- Provides a communication platform between a wide range of “smart” devices
- Not limited to “line of sight” communication

Motivation

Digital Camera



Computer



Scanner



Inkjet
Printer



Home Audio System

PDA
Cell Phone



Cordless Phone
Base Station

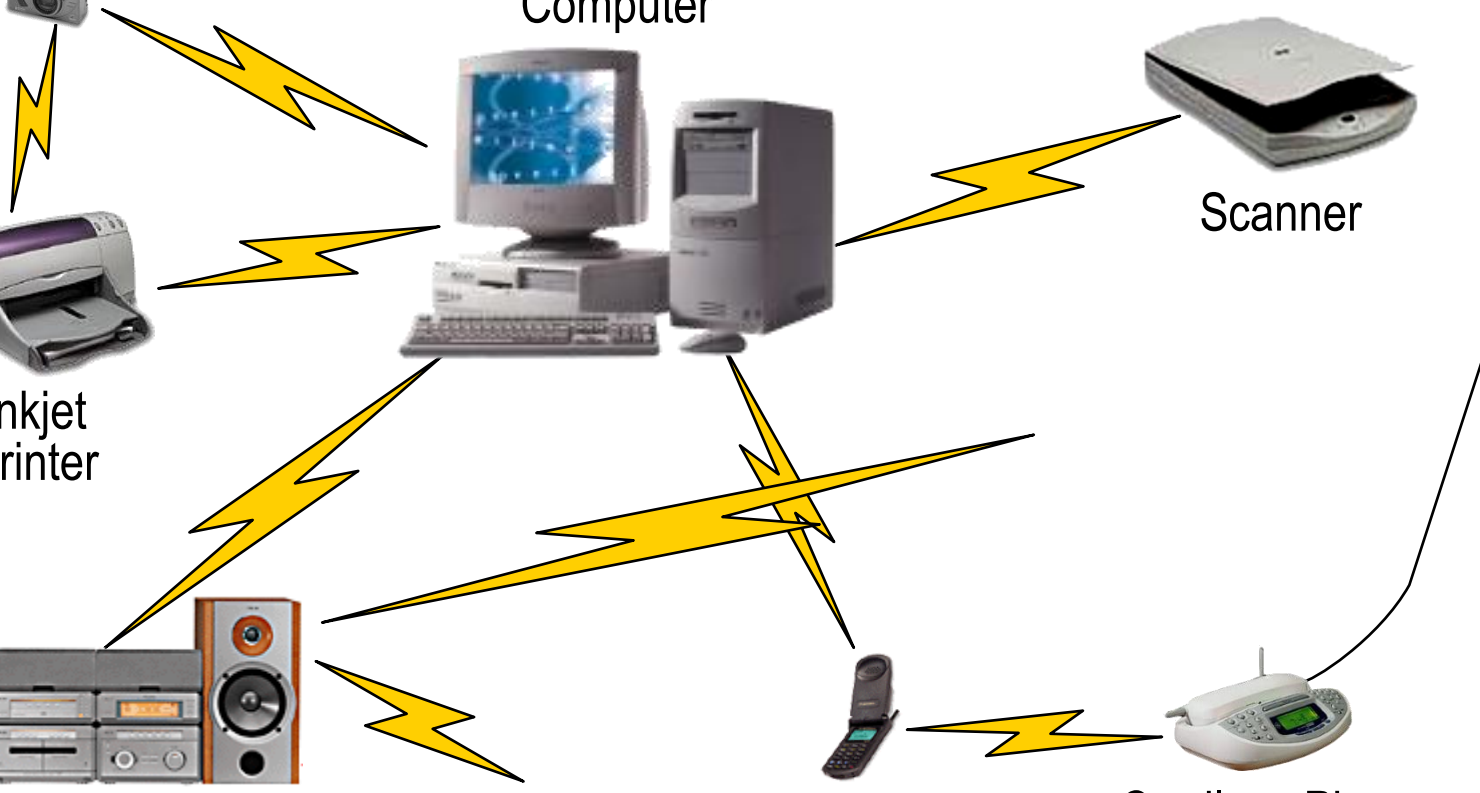



Bluetooth Applications

- Automatic synchronization between mobile and stationary devices
- Connecting mobile users to the internet using bluetooth-enabled wire-bound connection ports
- Dynamic creation of private networks



Synchronization

- Keep data on different devices synchronized without using a cable
- Example:
 - Walk into office and have your PDA synch with your laptop on your desk without even taking your PDA out of your briefcase



Connecting to Internet

- Being able to gain access to the Internet by using “Bluetooth access points”
 - Access point is used as a gateway to the internet
 - Both the access point and the device are Bluetooth-enabled
 - An example of Service Discovery Protocol
 - Access point provides a service to the device



Ad Hoc Networks

- Up to 8 devices can be actively connected in master/slave configuration
- Piconets can be combined to form scatternets providing unlimited device connectivity

Protocol Stack

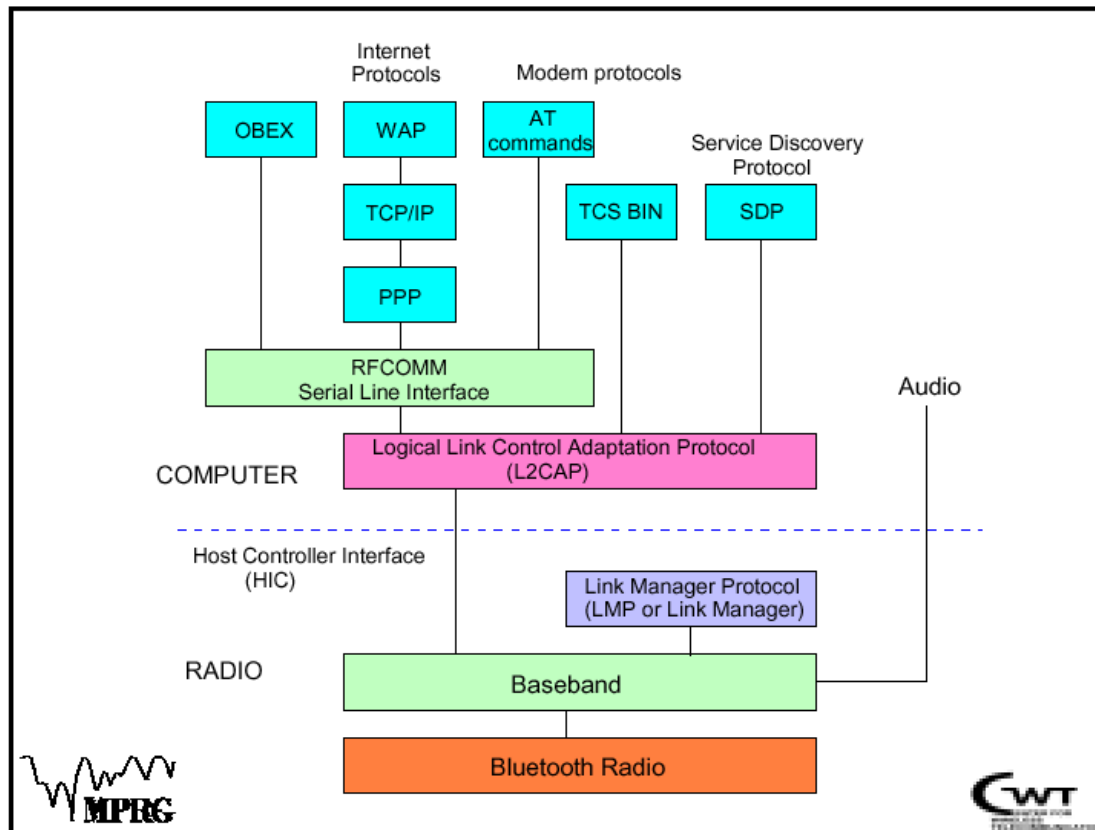



Bluetooth Radio

- Uses 2.4 GHz ISM band spread spectrum radio (2400 – 2483.5 MHz)
- Advantages
 - Free
 - Open to everyone worldwide
- Disadvantages
 - Can be noisy (microwaves, cordless phones, garage door openers)

Frequency Hopping

- In order to mitigate interference, Bluetooth implements frequency hopping
- 1600 hops per second through 79 1MHz channels
- Spreads Bluetooth traffic over the entire ISM band
- All slaves in piconet follow the master for frequency hop sequence

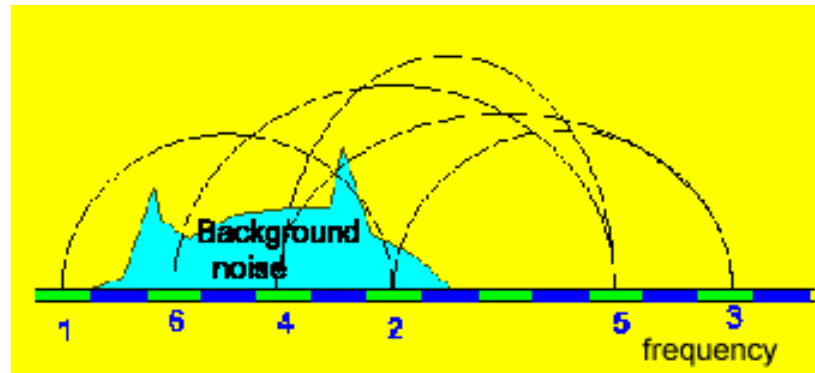

Frequency Hopping (cont.)

- Hops every packet
- Packets can be 1, 3, or 5 slots long (a slot is $625\mu\text{s}$)
- Packets are pretty short

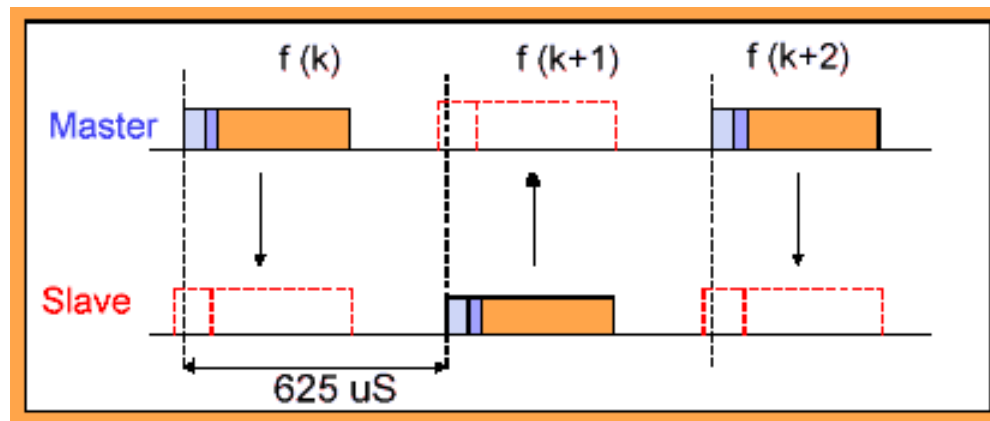



Baseband Layer

- Provides in-order delivery of byte streams
- Handles Frequency Hop Sequences for Synchronization and Transmission
- Establishes Links
 - Synchronous Connection Oriented (SCO)
 - Asynchronous Connection-Less (ACL)
- Provides functionality to determine nearby Bluetooth devices

Connection (Inquiry and Paging)

Link controller states during connection process

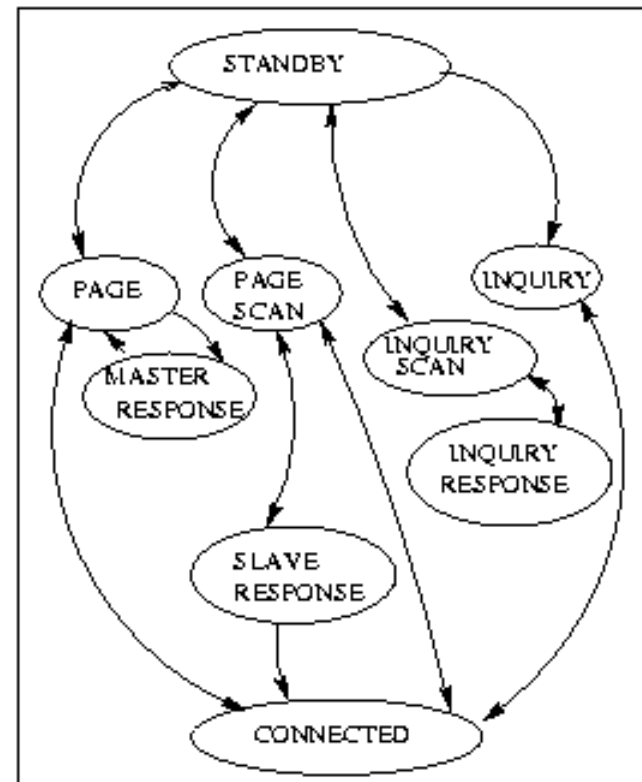



Bluetooth: Hello, Anyone Around?

- Inquiry Procedure
 - Sends out an inquire, which is a request for nearby devices (within 10 meters)
 - Devices that allow themselves to be discoverable issue an inquiry response
 - Can take up to 10.24 seconds, after which the inquiring device should know everyone within 10 meters of itself

Device Discovery Illustrated

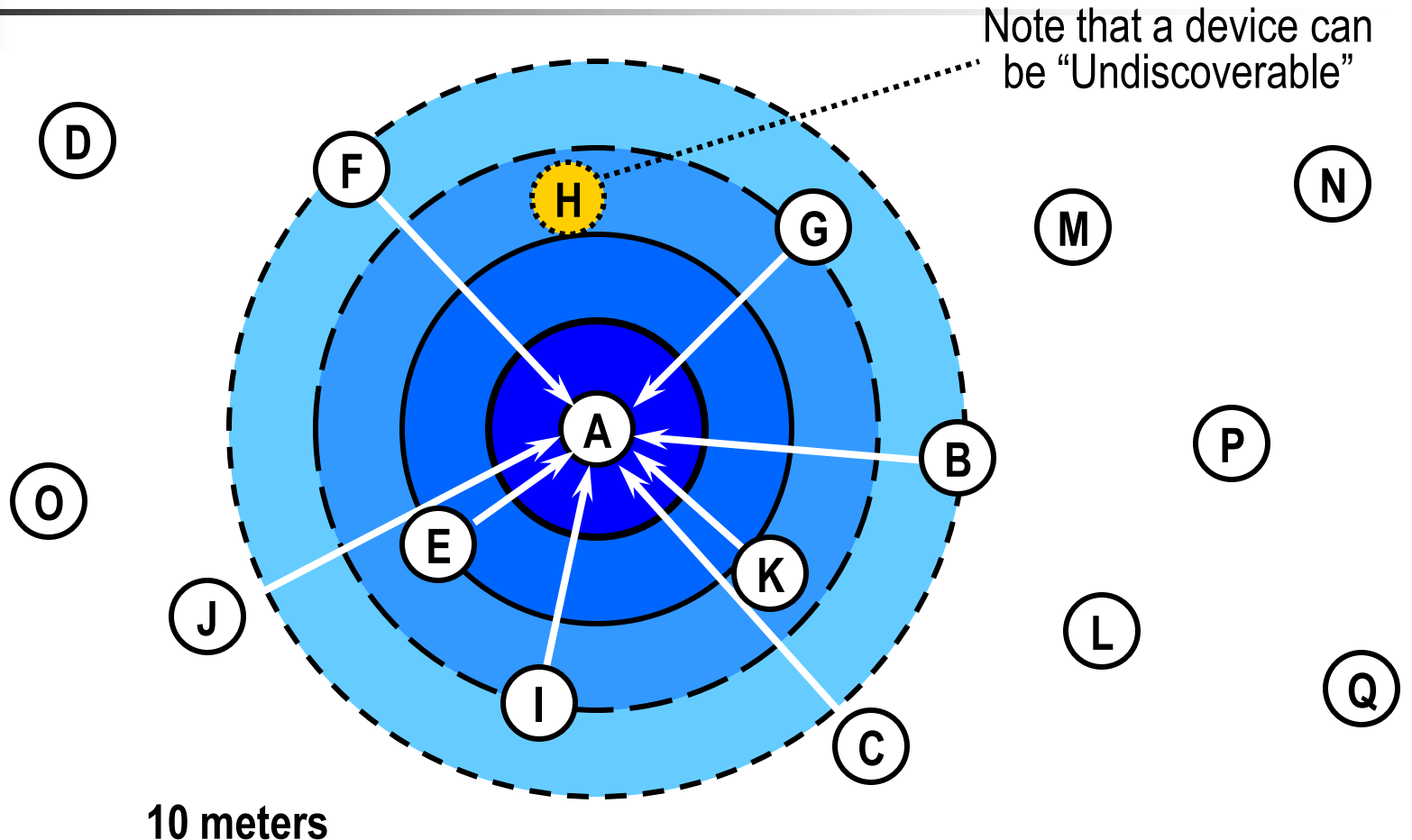

After inquiry procedure, A knows about others within range



Issues with Inquire Messages

- Are the inquirer transmitting and the receiver listening on the same frequency?
 - Since they are not yet connected, they are on totally different hop sequences, and most likely on different channels
- If they are on the same frequency, what if they are on a noisy channel?
 - Bluetooth provides the capability for receivers to issue multiple inquiry responses



Main Idea Behind Inquire

- Inquiring device sends out an inquire on 16 different frequencies (16 channel train)
- Receiver (device in standby mode), performs an inquire scan long enough for an inquiring device to send the inquire on 16 frequencies
- Receiver does an inquire scan frequent enough so that it is guaranteed to wake up during a 16 channel train

Inquiry Hop Train

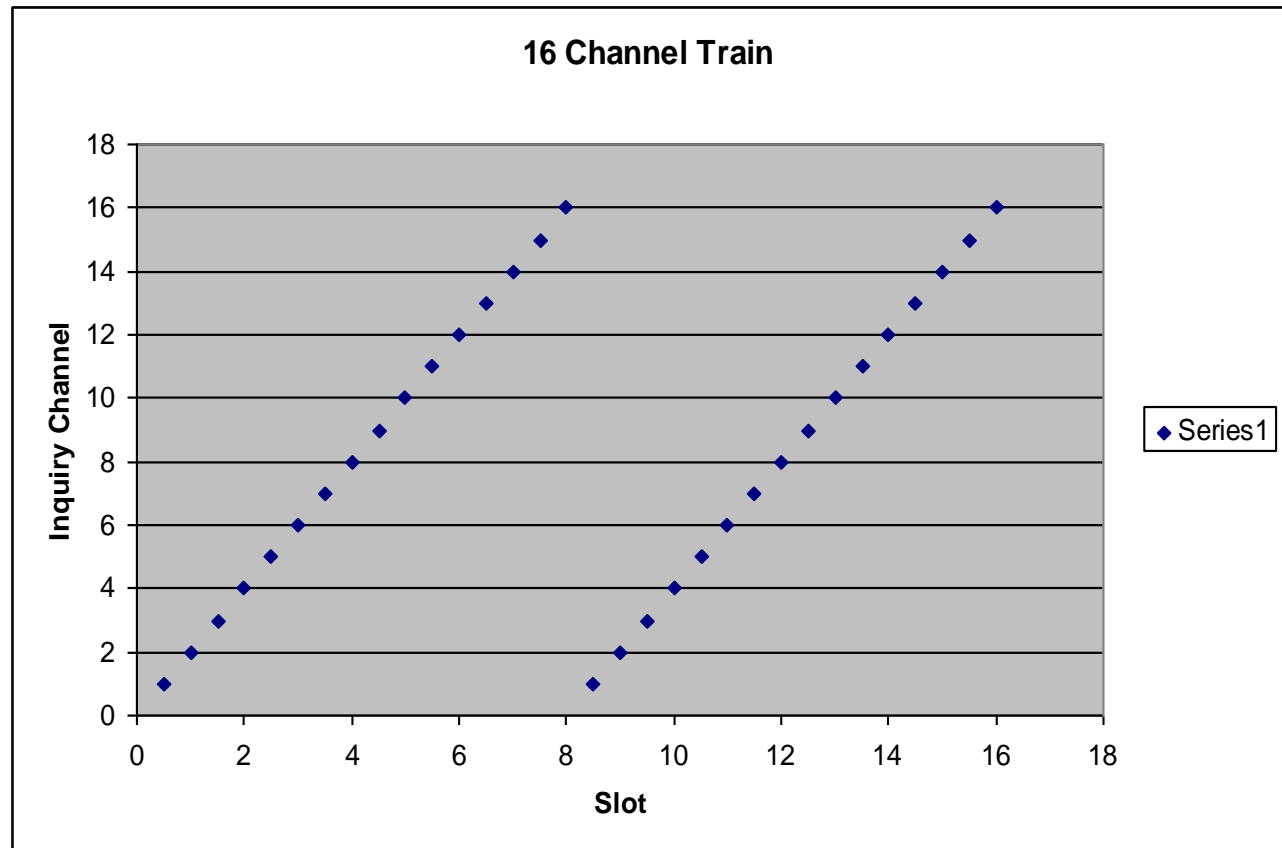



The Numbers Behind Inquire

- Each full scan of a 16 channel train takes about 1.28 seconds
 - $16 \text{ channels} * 625\mu\text{s} * 128 \text{ trains} = \underline{1.28 \text{ seconds}}$
- One full 16 channel train takes 10ms.
- Receiver enters inquiry scan state at least once every 1.28 seconds, and stays in that state for 10ms.



What about noise?

- Devices always reply to received inquiry messages with an inquiry response
 - An inquirer is allowed to receive multiple responses from one device
- In order to account for the fact that channels can be noisy and transmissions can get lost, the 128 train scan is repeated up to 4 times for each train (10.24 seconds)
 - Designed to successfully communicate at least once with all devices within range



Inquiry

- Uses 32 inquire channels to send out inquiry messages
- Send out inquiry on 32 channels, broken up into 2 inquiry hop trains (16 different channels to transmit packets)
- Intended to catch a device in inquiry scan mode on one of the 32 inquire channels



Inquiry Scan

- A device periodically listens for inquiry packets at a single frequency – chosen out of 16 frequencies
 - Inquiry hop sequence depends on device address
- Stays in the state long enough for a inquiring device to cover 16 frequencies
- Will re-enter inquiry scan state even after responding to an inquire



Inquiry Response

- When radio receives inquire, it will wait between 0 and .32 seconds before sending an FHS packet as a response
 - This is done to avoid collision with another radio that also wants to send an FHS packet
- FHS Packet contains:
 - Device ID
 - Clock
- After inquiring radio is done with inquiring procedure, it knows all of the radios (that are discoverable) within range



Paging: Will you connect to me?

- Very similar to inquire
- Still have not synchronized clocks or frequencies
- Establishes actual Piconet connection with a device that it knows about
- Connection process involves a 6 steps of communication between the the master and the slave

Step	Message	Direction	Hopping Pattern	Pattern Source and Clock
1	Slave ID	Master to Slave	Page	Slave
2	Slave ID	Slave to Master	Page Response	Slave
3	FHS	Master to Slave	Page	Slave
4	Slave ID	Slave to Master	Page Response	Slave
5	1st Master Packet	Master to Slave	Channel	Master
6	1st Slave Packet	Slave to Master	Channel	Master

Paging Illustrated

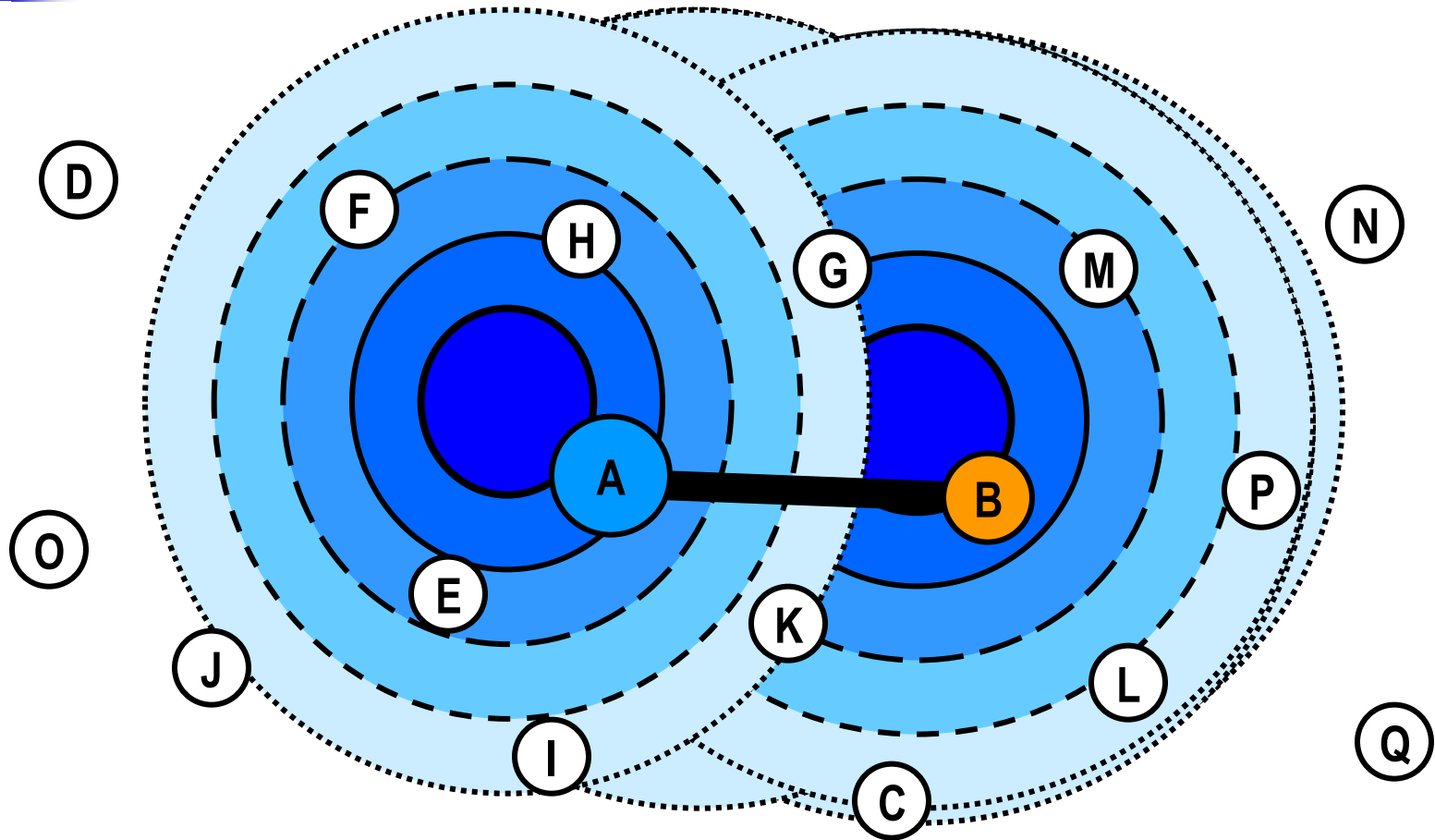

10 meters



Step 1: The Page Command

- Device broadcasts a page message out to the device that it wants to set up a connection with
 - Does this in a similar manner as inquire messages (on 2 frequency trains of 16 frequencies each)
- Once the device receives a page response, it will stop paging and move on to step 2



Paging: Steps 2 & 3

- Step 2: In the page response, an acknowledgement is sent back to the master containing the slave ID
- Step 3: In the master response, the frequency hopping generator is stopped and the master issues an FHS packet to the slave



Paging: Step 4

- The slave issues a final slave response transmission that is aligned to the slave's native clock
- Using the data from the FHS packet, the slave calculates and adopts the master's frequency hopping pattern and synchronizes to its clock



Paging: Step 5

- When the master receives the packet, it jumps back to its frequency hopping pattern and assigns the slave an Active Member Address (AMA) for the piconet
- Master sends out a poll packet to ensure that the slave is on its frequency hopping pattern



Paging: Step 6

- Once the slave receives the poll packet, the slave replies with any kind of packet to ensure that it is on the right channel
- The acknowledgement must be received by the Master within the timeout period
- At the conclusion of step 6, a new synchronized connection is established between the master and the slave



Link Manager

- Performs all link creation, management, and termination operations
- Responsible for all the physical link resources in the system
 - Handles the control and negotiation of packet sizes used when transmitting data
- Controls Operation Modes for devices in a piconet
- Sets up, terminates, and manages baseband connections between devices
 - Establishes different types of links dependent on requests from the L2CAP layer
 - Synchronous Connection-Oriented (SCO)
 - Asynchronous Connection-Less (ACL)



Asynchronous Connection-Less (ACL)

- Designed for data traffic
- Packet switched connection where data is exchanged sporadically as and when data is available from higher up the stack
- Data integrity is checked through error checking and retransmission
- One ACL link between a master and a slave

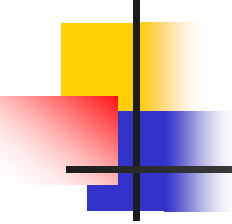

Synchronous Connection Oriented (SCO)

- Intended for use with time-bounded information such as audio or video
- Provides a circuit-switched connection where data is regularly exchanged
- Retransmission is not necessary, since data is real-time
- Up to 3 SCO links per piconet



ACL Links vs. SCO Links

	Intended Traffic Type	Retransmission	Max # links between master and slave	Supported during hold mode	Switched connection type
ACL	Data	Yes	1	No	Packet
SCO	Time bounded info (Audio or Video)	No	3	Yes	Circuit

ACL Setup Under LMP

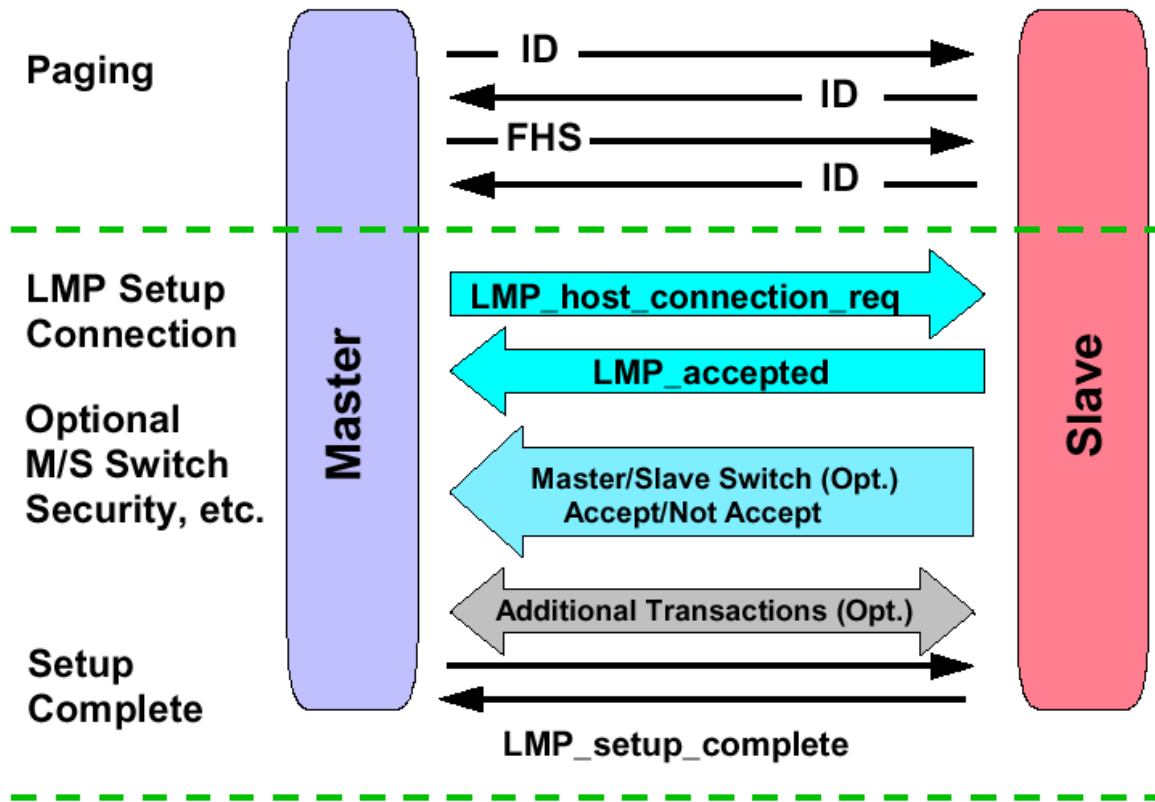

Establishing Piconets

- Whenever there is a connection between two Bluetooth devices, a piconet is formed
- Always 1 master and up to 7 active slaves
- Any Bluetooth device can be either a master or a slave
- Can be a master of one piconet and a slave of another piconet at the same time (scatternet)
- All devices have the same timing and frequency hopping sequence

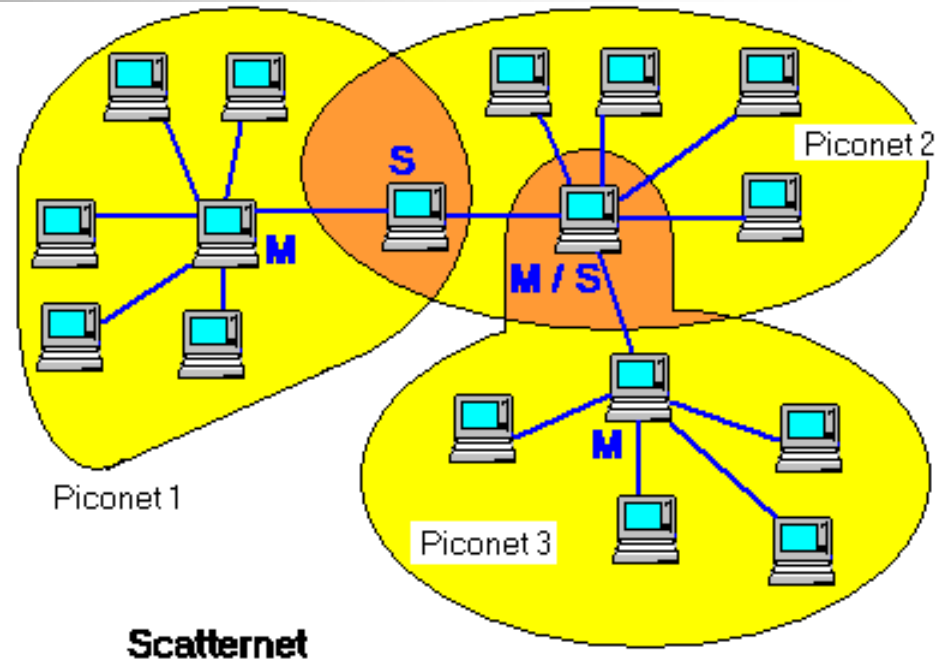

Scatternets

- Formed by two or more Piconets
- Master of one piconet can participate as a slave in another connected piconet
- No time or frequency synchronization between piconets

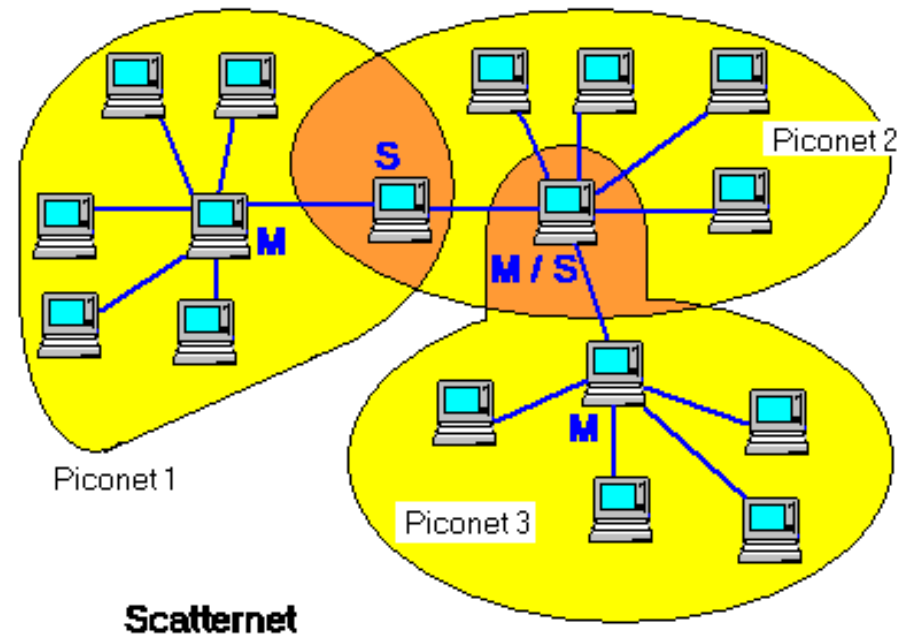



Link Manager Operation

- Devices operate in standby mode by default until they become connected to a piconet
- 4 Connection Modes
 - Active
 - Hold
 - Park
 - Sniff
- Modes allow devices to adjust power consumption, performance, and the number/role of participants in a piconet



Active Mode

- Limited to 7 Active slaves for each master
- Three bit address (AM_ADDR) given to each active slave
- Unit actively participates on channel
- Can receive communications in any given frame
- Active slaves are polled by master for transmissions
- Unit operates on high-power



Hold Mode

- Frees slave to
 - Attend another Piconet
 - Perform scanning, paging, or inquiry operations
 - Move into low-power sleep
- Unit keeps active member address
- Unit does not support ACL packets on the channel but may support SCO packets
- Master and slave agree on a one time hold duration after which the slave revives and synchronizes with channel traffic
- Unit operates on low-power



Sniff Mode

- Very similar to hold mode
- Slave is freed for **reoccurring** fixed time intervals
- Master can only communicate during arranged "sniff" time slots



Park Mode

- Parked unit gives up active member address and is assigned
 - 8 bit Parked member address (PM_ADDR) – allows master to unpark slave
 - 8 bit Access request address (AR_ADDR) – allows slave to ask master to unpark it
- Unit stays synchronized to channel
- Operates in very low-power sleep

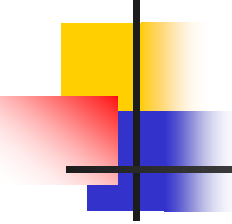

Park Mode (cont.)

- Provides the ability to connect more than 7 devices to a master (8 bit PM_ADDR allows 255 parked devices)
- Active and Parked slaves can be switched in and out to allow many connections to a single piconet

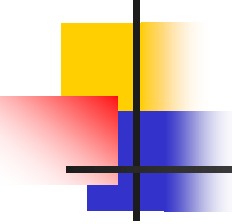

Park Mode (cont.)

- Master establishes a beacon channel and beacon interval when a slave is parked
- Parked slave wakes up at regular beacon interval to
 - Maintain synchronization
 - Listen for “broadcast” messages (packets with all zero AM_ADDR)
 - Potentially make access request to master through (AR_ADDR)



Park Mode (cont.)

- Beacon slots must have at least “null” master-to-slave traffic
- Master-to-slave transmissions may extend over multiple beacon slots



Security

- Link manager provides mechanism used by devices at either end of a link for
 - Negotiating encryption mode
 - Coordinating encryption keys
- Baseband handles encryption and key generation



Host Controller Interface (HCI)

- Most Bluetooth systems consist of two processors:
 - The higher layers of the protocol stack (L2CAP, SDP, RFCOMM) are run on the host device's processor
 - The lower layers of the protocol stack (Baseband and radio) are run on specific Bluetooth hardware
- HCI provides an interface between the higher and the lower layers of the protocol stack



HCI Flow Control

- Main function of the Host Controller Interface
- Many times higher layer protocols have data rates much larger than data rate across Bluetooth radio and air interfaces
 - Also need to handle the reverse situation when the host cannot accept data as fast as the Bluetooth module can send it



Two Pieces of HCI

- Host controller resides on Bluetooth hardware accepting communications over the physical bus (radio and air)
- HCI Driver resides on the host accepting communications from higher layer protocols

The basic structure showing how the host controller layers are fitted into the protocol stack

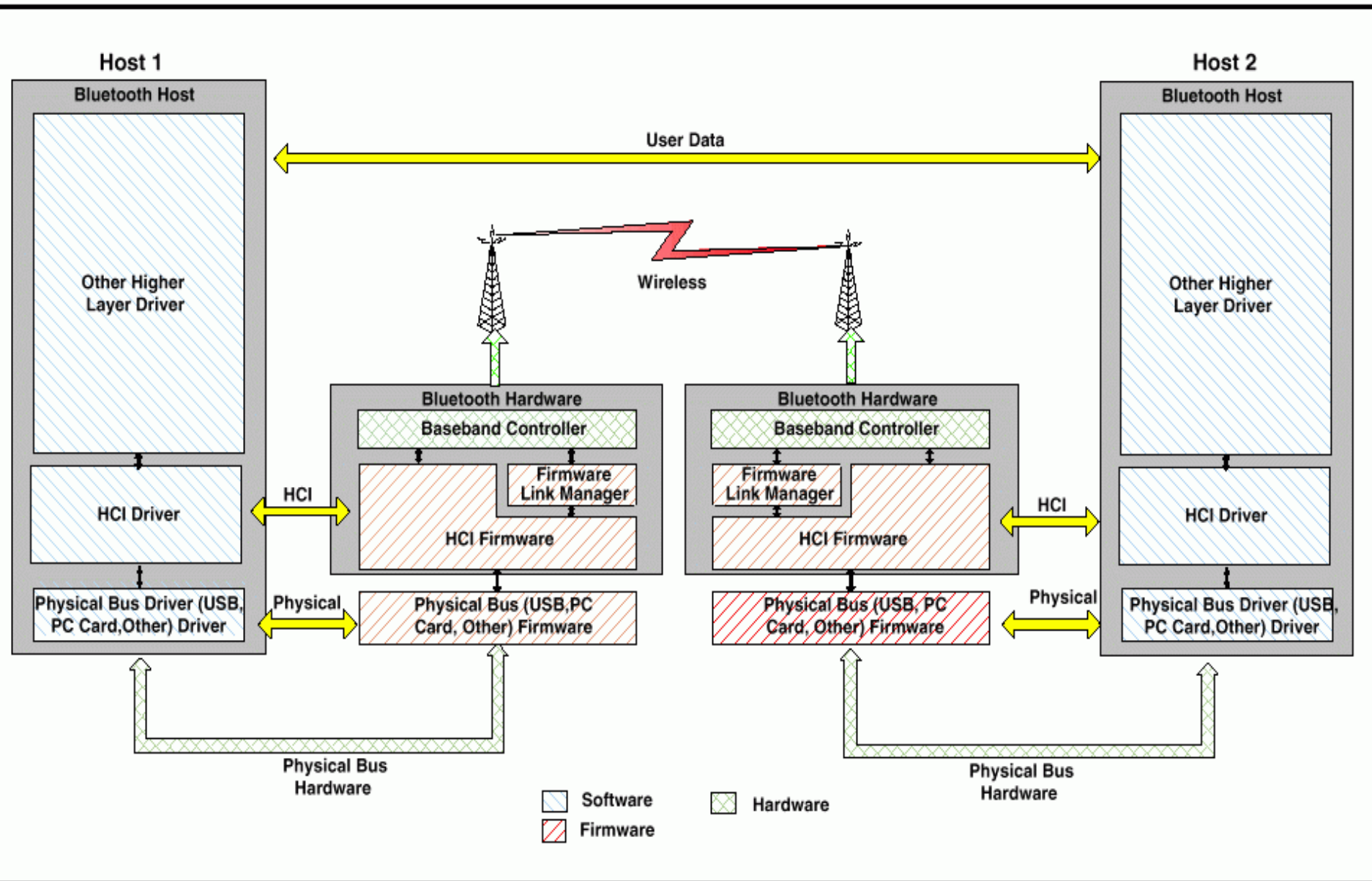



RFCOMM

- Cable replacement protocol allowing applications built to interface with serial port to function seamlessly with bluetooth
- Emulates serial port over the L2CAP protocol by specifying how a data stream can be emulated
 - RFCOMM actually handles parallel data



Emulating the Serial Port

- Typically, the receive and transmit lines are connected to a UART (Universal Asynchronous Receiver Transmitter)
 - Job of the UART is to convert between serial data sent down cables and the parallel data processing which devices use
- Since software that deals with serial ports view the data after it has been through UART, it only sees the parallel data
 - RFCOMM protocol only works with parallel data by connecting to the lower layers via L2CAP



Service Discovery Protocol (SDP)

Idea:

- Traditional LANs: Find a connection to a printer (or other resource) and keep that connection for a long time
- Bluetooth: Walk into an area, find a printer (or other resource), use it, then walk away forgetting any details of the connection



SDP Client/Server Model

- SDP Server is any Bluetooth device that offers services to other Bluetooth device (ex. Bluetooth-enabled printer, etc.)
 - Each SDP Server maintains its own database that contains information about the services that it offers
- SDP Client is any Bluetooth device that uses the services offered by an SDP Server

SDP in the Bluetooth Protocol Stack

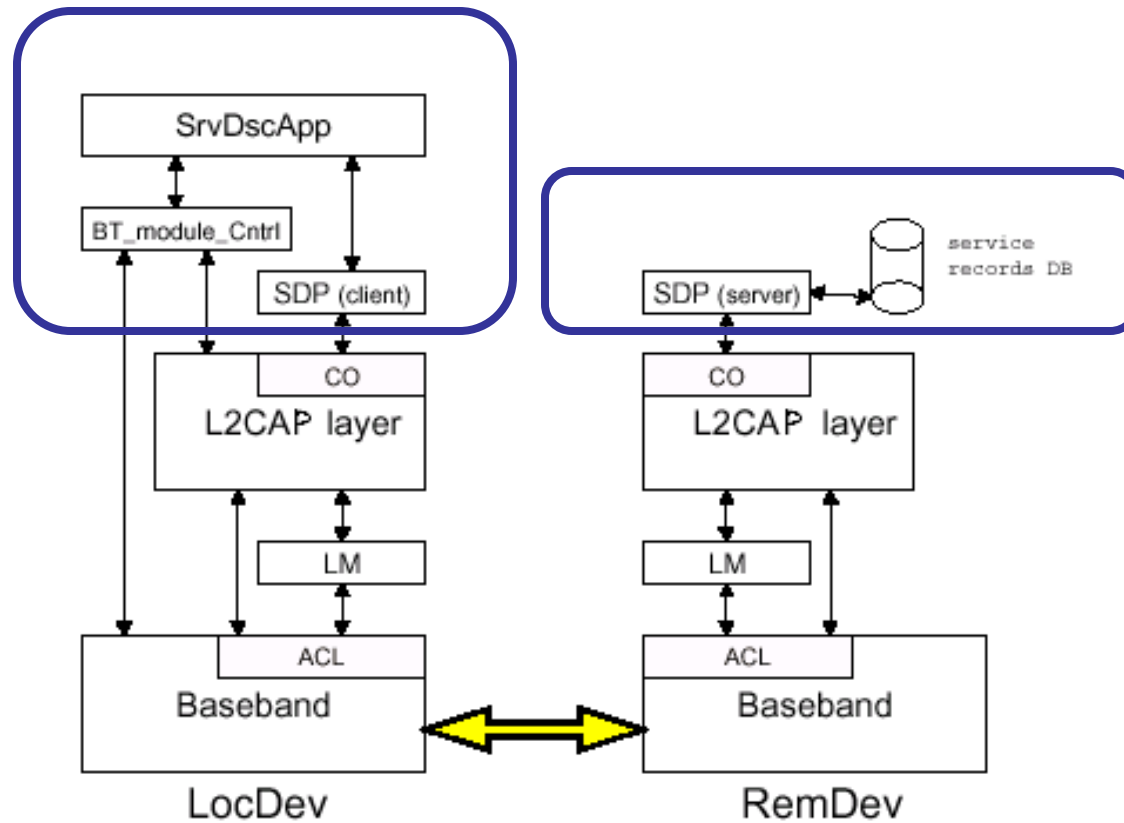



SDP Query

- The SDP client queries an SDP server to find out what services are available
 - Uses the L2CAP link that is set up between the client and the server
 - L2CAP link provides information on services but doesn't handle any connection to services
 - Need to specify a class of services that the client wants to use (e.g. printing services)



SDP Database

- SDP Database is a set of records that describes the different services that the server can provide to another Bluetooth device
- When the SDP server gets a query, it looks up the service that the client is requesting and returns information to the client on how to connect to the service



Using the Services

- The SDP client establishes a separate (non-SDP) connection to use the service
 - SDP connection is only used to determine service availability
- The L2CAP connection uses to get information for the service can be dropped (if no more services are needed) or retained (if the client still needs more services from the server)



Logical Link Control and Application Protocol (L2CAP)

- Performs 4 major functions
 - Managing the creation and termination of logical links for each connection through “channel” structures
 - Enforcing and defining QoS requirements
 - Adapting Data, for each connection, between application (APIs) and Bluetooth Baseband formats through Segmentation and Reassembly (SAR)
 - Performing Multiplexing to support multiple concurrent connections over a single common radio interface (multiple apps. using link between two devices simultaneously)



Segmentation/Reassembly

- Baseband packet size is limited
 - Can handle payload of 2745 bits
- L2CAP accepts packet size up to 64kb
- L2CAP segments large packets into smaller baseband manageable packets
- Smaller received baseband packets are reassembled coming back up the protocol stack



Quality of Service

- Applications may demand QoS on specific parameters
 - Peak bandwidth
 - Latency
 - Delay variation
 - Token rate
 - Token bucket size
- L2CAP provides requested QoS if possible and notifies application if link can not support demands



Protocol Multiplexing

- Applications may access L2CAP through different support protocols
 - Service Discovery Protocol (SDP)
 - RFCOMM
 - Telephony Control Protocol Specification (TCS)
- Baseband is not concerned with operation protocols meaning L2CAP must distinguish between them

Protocol Multiplexing Illustrated

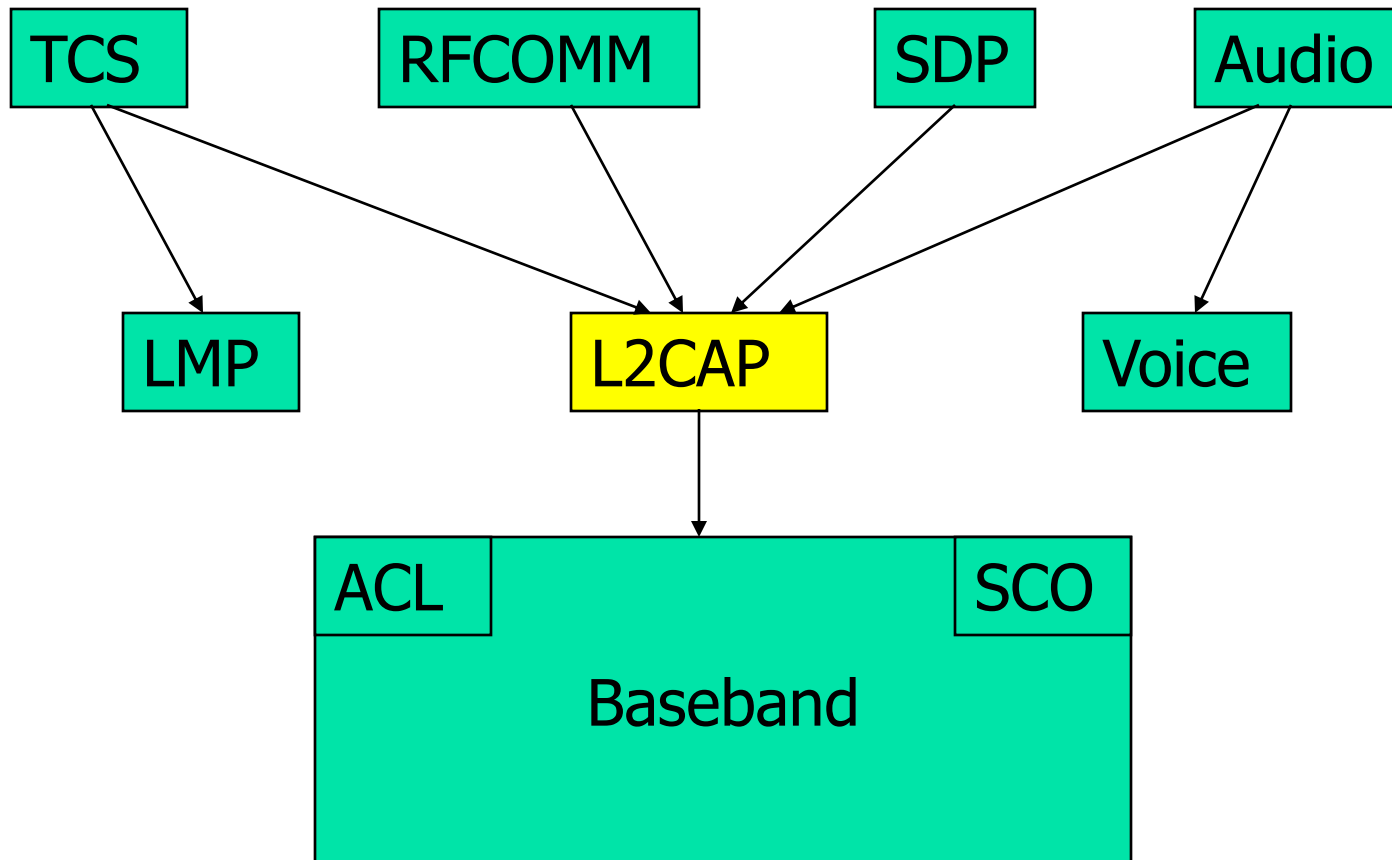



Summary

- Advantages of Bluetooth
 - Low power consumption
 - Low price on Bluetooth components
 - Non line-of-sight
- Disadvantages of Bluetooth
 - Wireless LANs offer faster data rates and larger communication ranges
 - Possibility of interference on 2.4GHz frequency band



Sources

- <http://www.cs.washington.edu/homes/seila/bluetooth.ppt>